

Radar Level Transmitter

SK-R800N

User's Manual (ver: 2.0)

MC Shaanxi 01000373

IPA 13L169-61



Catalogue

1. Radar Level Transmitter Warranty and Service Scope	1
2. Unpacking Inspection and Precautions	2
2.1 Unpacking inspection	2
2.2 Precautions	2
3. Storage and Transportation	3
3.1 Storage condition	3
3.2 Transport the product to the measuring location	3
4. Product Description	4
4.1 Product overview	4
4.2 Technical Parameters	5
5. Scope of application	6
5.1 Medium	6
5.2 Radar Level Transmitter ambient temperature	6
5.3 Explosion-proof and protection level	6
6. Radar shape structure	7
6.1 Radar level transmitter shape structure	7
7. Radar Level Transmitter interface	8
8. Radar debugging parameter description	9
8.1 Parameter setting man-machine interface	9
8.2 LCD main interface of Radar Level Transmitter	10
8.3 LCD Wave interface of Radar Level Transmitter	10
8.4 Radar Level Transmitter parameter menu	11
8.4.1 User parameter menu description	11
8.4.2 User Parameter setup scope and definition	11
9. Wire connection	13
10. Modbus (RS485) connection	13
11. Radar Level Transmitter installation and Debugging	14
11.1 Preparation before installation	14
11.2 Radar Level Transmitter installation location selection	15
11.3 Software configuration instructions	17
12. Maintenance and Repair	19
13. Fault handling	20

1. Radar Level Transmitter Warranty and Service Scope

Since the date of shipment, the Radar Level Transmitter has a one-year warranty. This warranty is limited to the original purchaser or the user of the designated dealer and does not apply to any human reasons. Such as the transmitter has been damaged due to misuse, alteration, negligence, or accident, or abnormal use.

Free repairs are provided for faulty Radar Level Transmitter returned within the warranty. For the customer who wants to obtain the warranty service, please contact the after-sales service department and attach a description of the fault. After permission from our company, send the radar to the after-sales service department.

If the Radar Level Transmitter has expired or it is confirmed that the malfunction is caused by misuse, modification, negligence, accident and use under abnormal conditions, a maintenance cost budget will be provided according to the relevant maintenance fee standard, and maintenance will be carried out after approval. After the Radar Level Transmitter is repaired, it is sent back to the customer, and the customer needs to pay for the repair and transportation costs.

2. Unpacking Inspection and Precautions

2.1 Unpacking inspection

- User manual
- Radar Level Transmitter certificate
- Radar Level Transmitter packing list
- Radar Level Transmitter
- Check the name, model, etc. on the nameplate
- Check whether the shell is in good condition, and observe whether the glass cover of the display screen is broken
- Check other accessories according to the packing list

Check whether the specifications, models and accessories are correct and complete according to the Radar Level Transmitter packing list. If you have any questions, please contact the customer service center for replacement.

2.2 Precautions

- Please read this manual before installing the Radar Level Transmitter.
- Modifications due to product upgrades will not be notified please refer to the actual product.

3. Storage and Transportation

3.1 Storage condition

- Allowable storage temperature: $-40^{\circ}\text{C} \sim +80^{\circ}\text{C}$
- Use the original packing.

3.2 Transport the product to the measuring location

- Transport the measuring equipment to the measuring location within the original packing.
- Prevent collision, moisture and chemical corrosion during transportation and storage.

4. Product Description

4.1 Product overview

76-81GHz frequency modulated continuous wave (FMCW) radar product (also called millimeter wave radar), using millimeter wave band with higher frequency than Ku-band radar, long-distance imaging and multi-spectral imaging in remote target detection and strong smoke and dust environment. It has important applications, and can detect smaller targets than microwave radar and achieve more precise positioning, with higher resolution and stronger confidentiality.

As a 80GHz band radar used in the industrial measurement field, It has the incomparable advantages of other ordinary microwave pulse radars and guided wave radars. The extremely narrow beam and penetrating ability are more effective. Adapt to ultra-complex working conditions without compromising measurement performance.

4.2 Technical Parameters

Radar Level Transmitter	Two-wire system
Working Frequency	76-81GHz
Measuring range	0~60m
Accuracy	±0.02%FS
Signal output	4~20mA
Power supply	DC 24V (18V~36V)
Process pressure	-1~3bar
Communication	HART Bluetooth
Ambient temperature	-40℃~+80℃
Storage temperature	-40℃~+80℃
Ambient humidity	(0%~95%) RH
Explosion-proof mark	Ex db ia IIC T6 Gb
Electrical Interface	M20×1.5(F), 1/2NPT
Beam Angle	±4° (1.5")/±2.9° (2")/±1.9° (3")
Display	128 × 64 LCD Screen, Debug module
Debugging Methods	Local display/ PC programme
Size	diameterφ96mm × Height221mm
Mounting thread	G1" 、 G1.5" 、 G2" 、 1" NPT、 1.5" NPT、 2 "NPT
Lens	PTFE
Mounting Method	Stainless steel flange / plastic flange
Migration/Offset	±9.9m
Weight	2KG
Protection level	IP65
Sealing material	FKM
Housing	Cast Aluminum
Optional accessorizes	Flange (SS304/SS316/PTFE/PP)

5. Scope of application

5.1 Medium

In general, the dielectric constant of the measured medium is required to be greater than “4”, so that it can have a good reflection section.

5.2 Radar Level Transmitter ambient temperature

The ambient temperature range of the Radar Level Transmitter is: $-40^{\circ}\text{C} \sim +80^{\circ}\text{C}$. It is recommended to use the instrument protection box in the northern area. In areas with strong direct sunlight, it is recommended to install the instrument in a cool place or use a sun visor, so as to avoid excessive temperature in the instrument caused by exposure to the sun, and to provide good ventilation and heat dissipation.

5.3 Explosion-proof and protection level

The Radar Level Transmitter adopts an explosion-proof structure with aluminum alloy casting and sealing and epoxy spraying on the surface.

Suitable for harsh environments containing explosive mixed gases, medium-concentration corrosive gases and “0-95%” humidity range.

Explosion-proof grade: Ex db ia IIC T6 Gb.

6. Radar shape structure

6.1 Radar level transmitter shape structure

- Radar level transmitter shape structure figure is shown as in Figure 1.

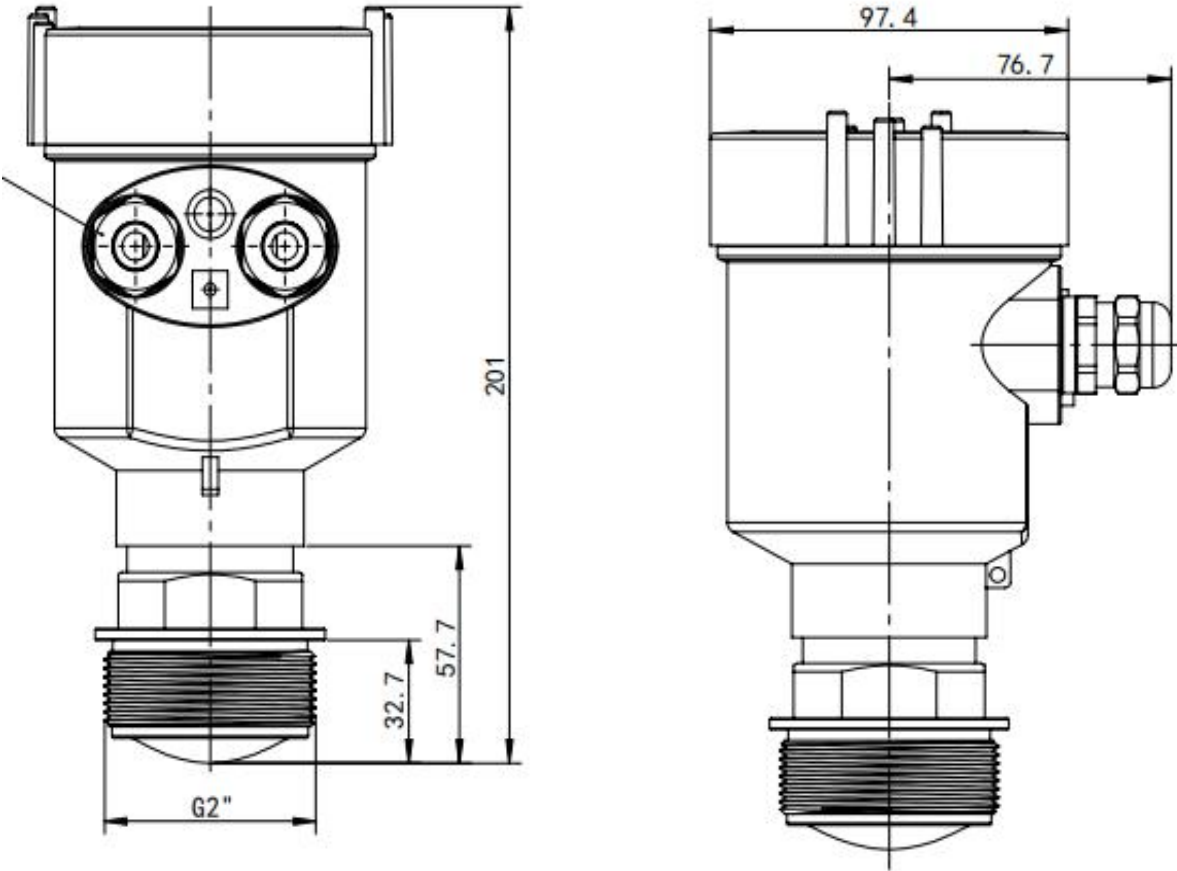

Figure 1 Radar level transmitter shape structure

7. Radar Level Transmitter interface

- Radar Level Transmitter interface figure is shown as in Figure 2.

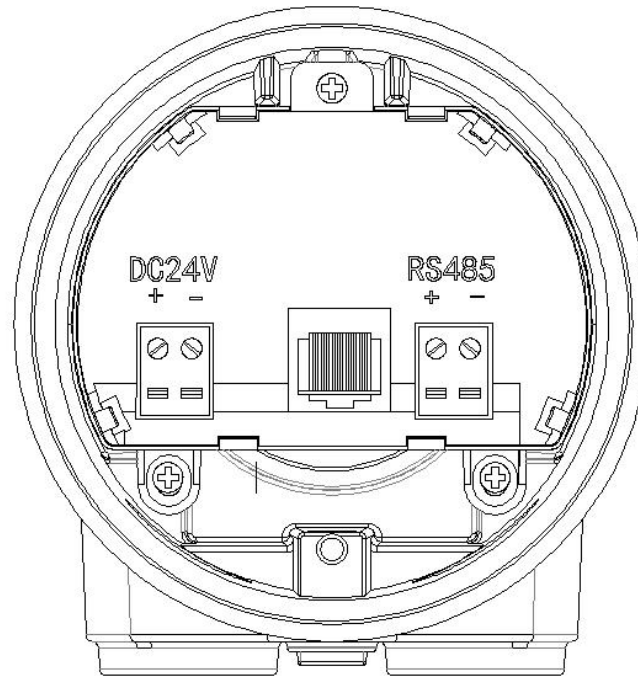

Figure 2 Radar Level Transmitter interface figure

- **Interface description**

Interface	Description
DC 24V (+)	24VDC(+)Power supply positive
DC 24V (-)	24VDC(-) Power supply negative
RS-485 (+)	RS - 485 communication positive
RS-485 (-)	RS - 485 communication negative

8. Radar debugging parameter description

8.1 Parameter setting man-machine interface

The radar uses a key-mode for parameter setting, and the key functions are shown in Figure 3.



Figure 3 key mode figure

Key function:

Key	Function
ESC	Back / Enter echo wave interface
UP	Up shift/ Increase key
DN	Down shift / Decrease key
OK	OK key / Enter setting parameter interface

8.2 LCD main interface of Radar Level Transmitter

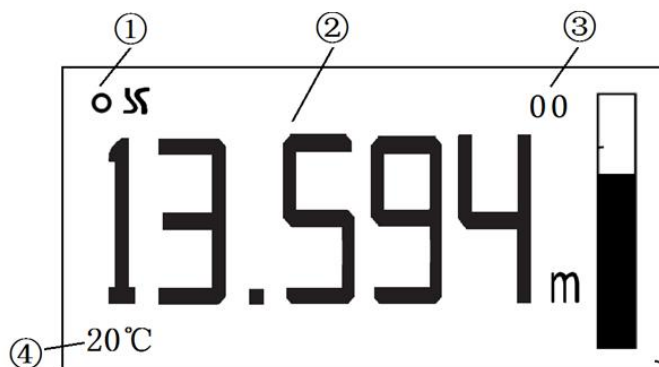

Figure 4 LCD main interface of Radar Level Transmitter figure.

①	Work instructions	Flashing reminder when working
②	Level display	Level value (m/mm/cm/inch/ft)
③	Error code	00: No error (Does not show error) 01: No target detected 02: Level value jumped 08: Communication error
④	Temperature	Display the temperature value when the temperature display function is turned on.

8.3 LCD Wave interface of Radar Level Transmitter

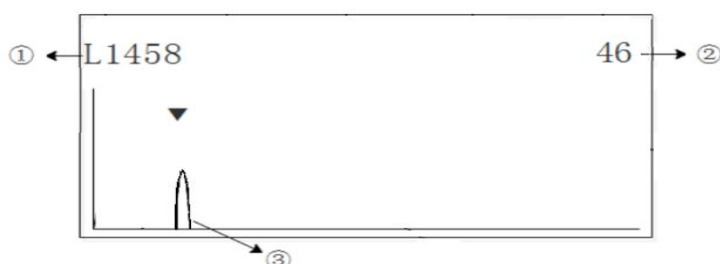

Figure 5 LCD wave interface of Radar Level Transmitter figure.

①	Gap value
②	Echo quality

③	Echo position
---	---------------

8. 4 Radar Level Transmitter parameter menu

8. 4. 1 User parameter menu description

User Para	Basic setup	Range
		Migration/Offset
		Show Type
		Pos: 4ma
		Pos: 20ma
		Blind area
		Damping Time
		Device ID
		Baud Rate
	Backup Para	
	Restore Para	

8. 4. 2 User Parameter setup scope and definition

Basic setup:

Range (500~50000) mm: Depends on the working conditions; indicates the farthest distance that the radar can measure.

Offset (-9999~9999) mm: Depends on the working conditions.

Show Type: Level /Ullage.

(Pos: 4ma): Level corresponding to 4mA current output, unit: mm.

(Pos:20ma): Level corresponding to 20mA current output, unit: mm.

Blind area: The value range is “200mm” to the measuring range, which can be

set according to specific working conditions.

Damping time: In order to improve the stability of the measured output value, a larger [Damping time] can be set to stabilize the measured value and increase the anti-interference ability. For example, if the damping time is “10”, the measured level changes step by step at time “t”, and the measured output value will follow the actual position of the measured object after “10” seconds.

Device ID: The address of the slave during RS485 communications, that is, the address of the local machine (value range: “1-99”, the default value is “1”).

Baud rate: The baud rate of this machine during RS485 communications is “9600” by default. Please do not change the default value.

Backup Parameter:

After the working parameters are backed up, if you forget the original working parameters after manually modifying the parameters and forget the original working parameters, you can "**Restore Parameter**" in the menu.

Restore Parameter:

Used to restore the backed up user parameters.

9. Wire connection

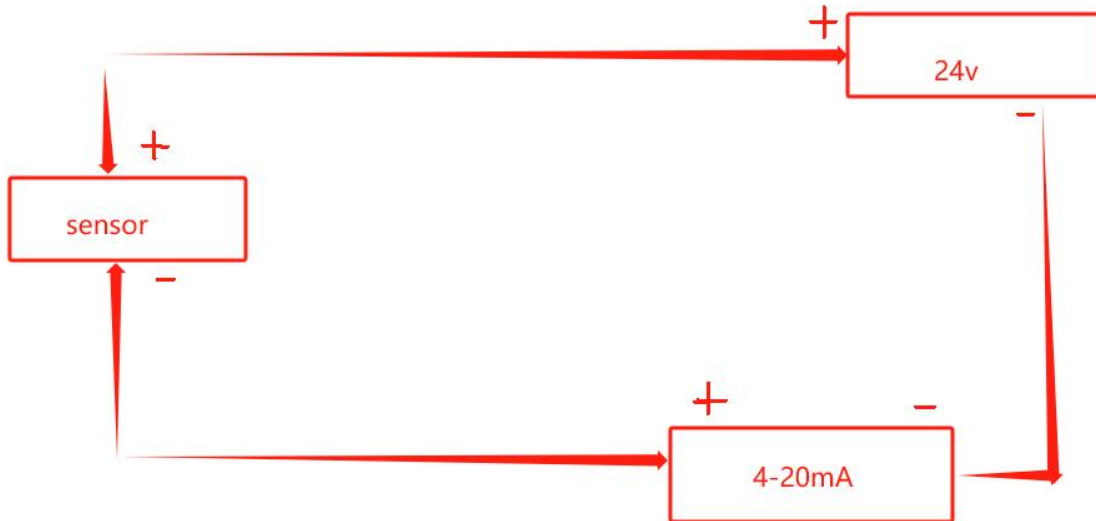

10. Modbus (RS485) connection

The screenshot shows the ShortBus Modbus Scanner v3.0 - Read Window 1 interface. The configuration parameters are as follows:

- Connection: COM1
- Node Address: 1
- Baud: 9600
- Parity: None
- Stop Bits: 1
- Starting Addr: 2
- Length To Read: 5
- Char Delay (ms): 6000
- Poll Delay (ms): 6000
- Read Function: FC 3 - Read 4x (Holding Regis)
- Result Format: Unsigned Integer 16-Bit
- Byte Order: Normal

The data returned from the sensor is displayed in the following table:

Address	Value	Label
400002	7404	Distane
400003	12000	Range
400004	0	OffSet
400005	9600	BaudRate
400006	1	Node Address

The interface also includes buttons for Connect, Disconnect, Reset Poll Counters, Open New Read Window, and Write Multiple. The status bar shows Total Pol: 52 and Valid Pol: 37.

1: Read Paras, Use Command 0x03

Register List:

Address	Description	Data Type	Remark
0002H	Current Level	16 bit unsigned integer	Unit: mm
0003H	Measure Range	16 bit unsigned integer	Unit: mm
0004H	Base Offset	16 bit signed integer	Unit: mm
0005H	Baudrate	16 bit unsigned integer	Unit: bps
0006H	Device ID	16 bit unsigned integer	Value: 1-255

2: Write Paras, Use Command 0x10

Register List:

Address	Description	Data Type	Remark
0003H	Measure Range	16 bit unsigned integer	Unit: mm
0004H	Base Offset	16 bit signed integer	Unit: mm
0005H	Baudrate	16 bit unsigned integer	Unit: bps
0006H	Device ID	16 bit unsigned integer	Value: 1-255

11. Radar Level Transmitter installation and Debugging

11.1 Preparation before installation

- Understand the internal structure and pipeline arrangement of the storage tank, and obtain information such as the diameter and range of the tank.
- Tools needed: flat-blade screwdriver (3*75mm), wire stripper (7mm²), hand-held knife, pipe wrench, DC 24V power supply.
- When the tools are ready, unpack the product and check the packing list to determine whether the materials are complete.

11.2 Radar Level Transmitter installation location selection

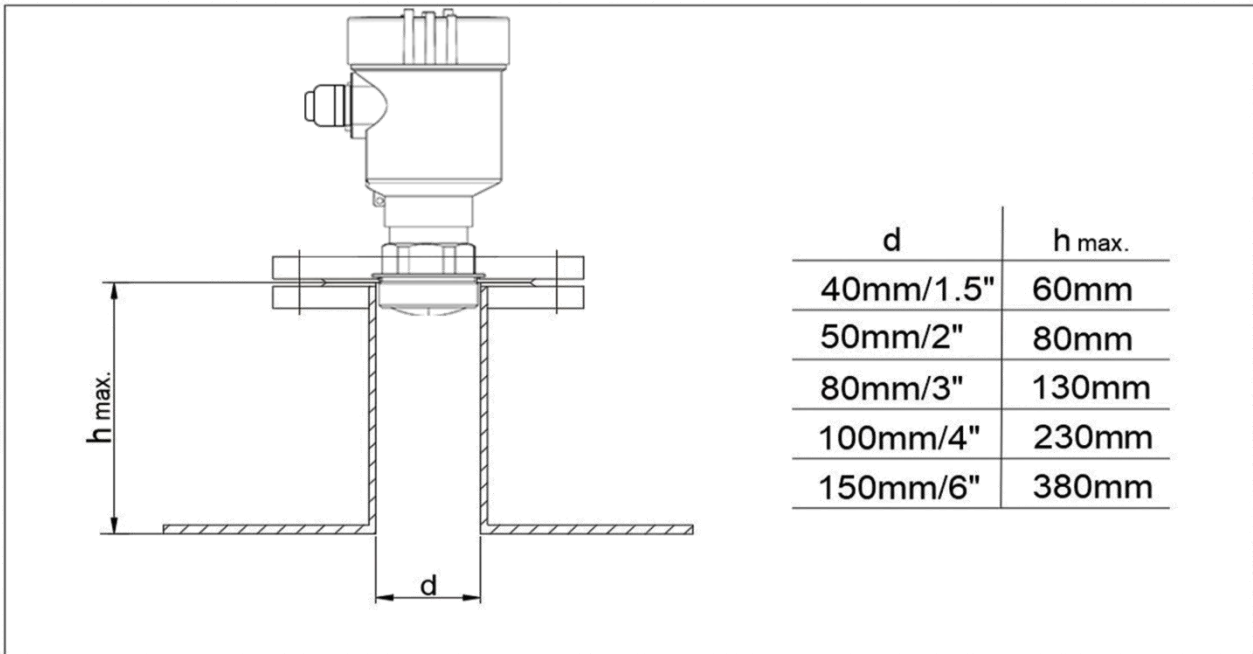

- Avoid installing the radar in a central location or close to the edge of the container, otherwise it is likely to produce false readings.

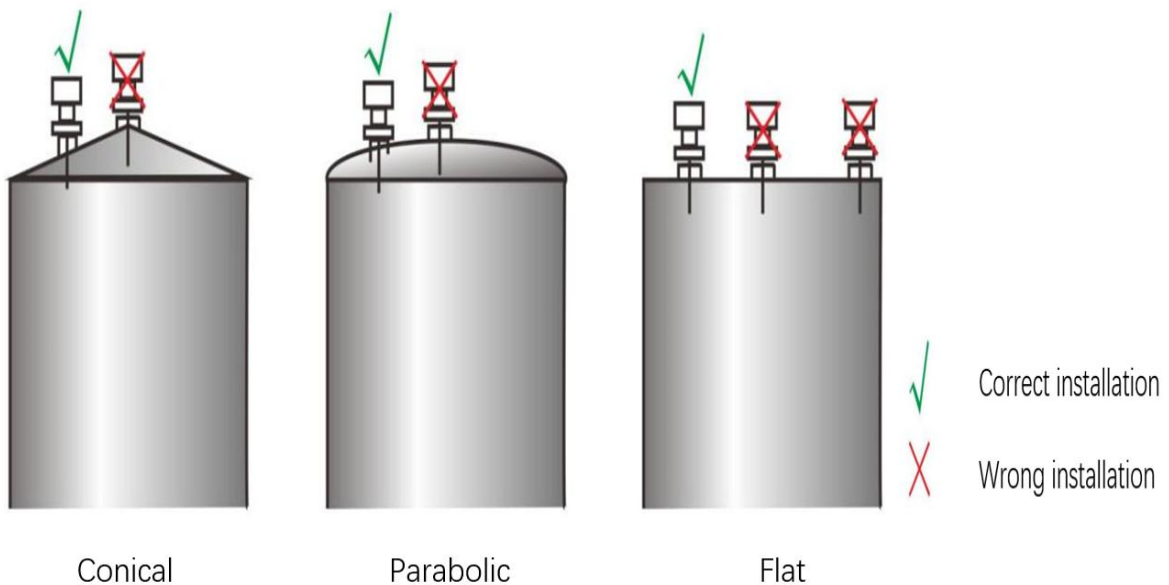
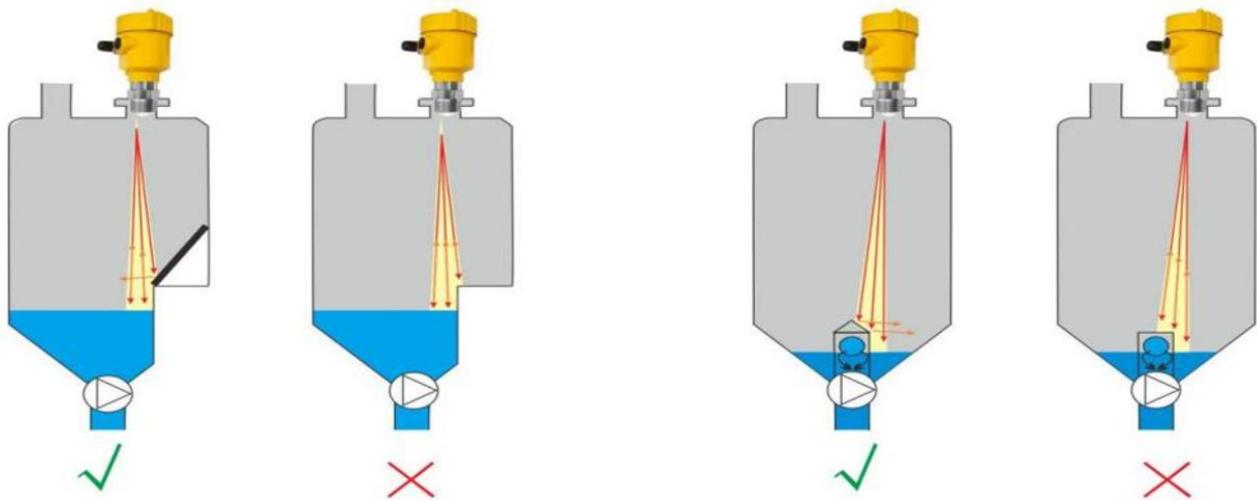

Figure 6 Radar installation location diagram

● Avoid false wave diagram



Avoid false wave examples

Figure 7 False wave diagram

● Treatment of stairs and grille tanks

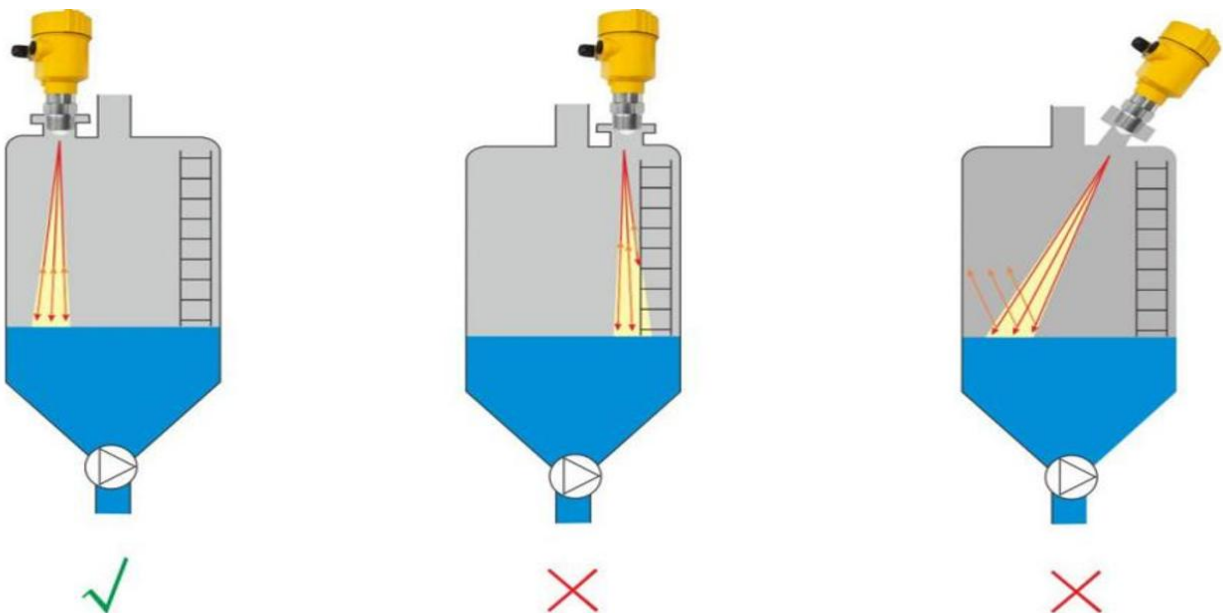

Treatment of stairs and grille tanks

Figure 8 Treatment of stairs and grille tanks diagram

- Treatment of wall hanging and grille tanks

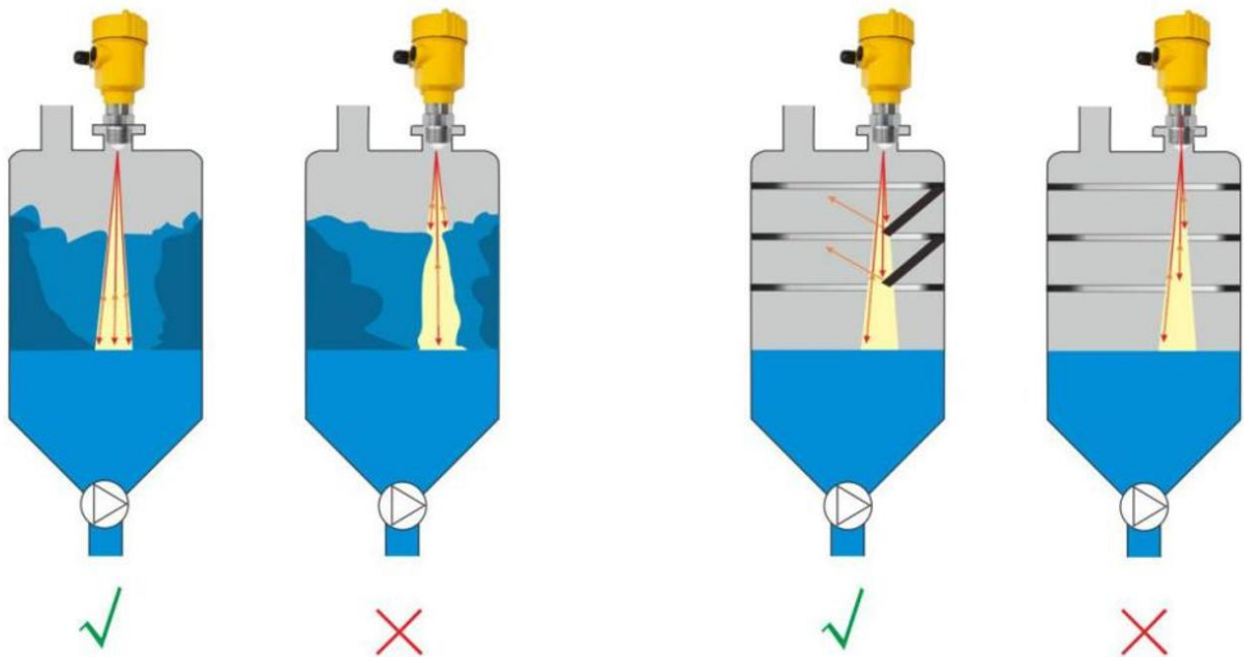

Treatment of wall hanging and grille tanks

Figure 9 Treatment of wall hanging and grill tanks diagram

11.3 Software configuration instructions

- Instrument connection

The power cord is connected to the DC24V terminal of the instrument, please pay attention to the positive and negative poles, and do not connect them wrongly.

- Set instrument parameters

Facing the display window of the instrument, press the "OK" button, the transmitter will display "Main menu" , as shown in the figure below:

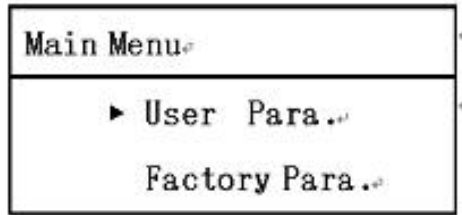

Press the "OK" button to enter the "User Para".

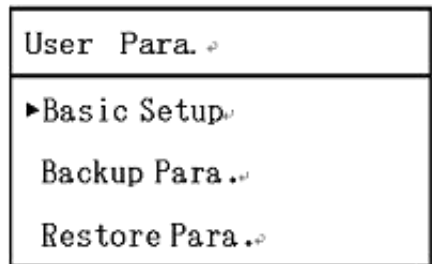

Press "OK" button to enter "Basic Setup".

Basic Setup	Basic Setup	Basic Setup
▶ Range: 10000 mm	▶ Pos 20ma: 10000 mm	▶ Damping Time: 200
Offset: 0 mm	Blind: 200 mm	DeviceID: 1
Pos 4ma: 0 mm	ShowType: Level	BaudRate: 9600

Set the "Range" according to the working conditions, press "OK", after the range value is reversed, use the "Upshift" and "Downshift" button to input the range value, and then press the "OK" button to confirm.

Press "Downshift" button to select "Offset", press "OK" to reverse the migration value, enter the migration value, and press "OK" to confirm.

The same steps can be used to modify:

"Pos: 4ma"

"Pos: 20ma"

"Blind area"

"Damping Time".

After the modification, press the "**Backspace**" key to return to the "**User Para**" interface.

When the display type is set to level, the main interface shows the actual level value. When the display type is set to Ullage, the main interface displays the Ullage measured by the radar. Set the display type as required.

Pos:4ma and **Pos:20ma** must be within the range. The relationship between the 4mA position, 20mA position and the range is shown in the figure below:

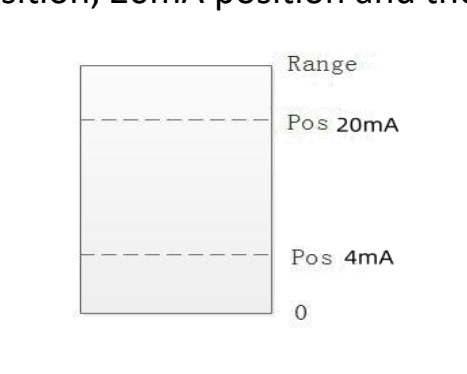

If the level lower than **Pos: 4ma**, the main interface shows that the level is "0", and if the level higher than **Pos: 20ma**, the main interface shows that the level is **Pos:20ma**.

12. Maintenance and Repair

- Please pay attention to keep the Radar Level Transmitter clean, try to be waterproof, moisture-proof, corrosion-proof and avoid violent collisions and blows from other objects.
- Please avoid direct sunlight to the main body of the Radar Level Transmitter,

stay away from heat sources and pay attention to ventilation. If the ambient temperature exceeds the rated temperature, appropriate cooling protection measures should be taken.

- When the ambient temperature is too low, an instrument protection box or other protective devices can be used for anti-freezing protection, and pay attention to keeping the radar level transmitter dry.
- The radar level transmitter should be checked regularly.(The detection cycle is determined by the user according to the specific situation)

13. Fault handling

Errors	Reason	Solution
No display	Power supply error	Check whether the DC 24V voltage and current meet the requirements.
	Wiring error	Check if the wiring is correct.
Value unstable	Too much fluctuation	Change the installation position of the radar or reduce the fluctuation of the object to be measured.
	Weak Signal	Try angle calibration or rotate the radar installation position.
	Strong electromagnetic interference	Connect the instrument to the ground or shield.

Error code:

E01: Liquid level not found.

E02: Liquid level jump is too large.

E04: Abnormal capacitor charging.

E40: Screen communication failure.

E08: Actual liquid level does not match 4-20mA position.(High, Low)